

Product Specification Sheet

OLSCxx12L-C(I)D20

RoHS Compliant 1.25Gbps CWDM 1270nm~1610nm Optical Transceiver 20km Reach



Product Features

- Supports bit rates up to 1.25Gbps
- Duplex LC connector
- Hot pluggable SFP footprint
- CWDM 1270nm~1610nm laser transmitter and PIN photo-detector
- Applicable for 20Km SMF connection
- Low power consumption, < 0.825W
- Digital Diagnostic Monitor Interface
- Compliant with SFP MSA and SFF-8472
- Very low EMI and excellent ESD protection
- Operating case temperature:
Commerical: 0 to 70 °C
Industrial: -40 to 85 °C

Applications

- Gigabit Ethernet
- WDM systems
- Switch to Switch interface
- Switched backplane applications
- Router/Server interface
- Other optical transmission systems

Product Descriptions

Olinkphotonics' OLSCxx12L-C(I)D20, The SFP transceivers are high performance, cost effective modules supporting data-rate of 1.25Gb/s and 40km transmission distance with SMF. The transceiver consists of three sections: an uncooled CWDM DFB laser transmitter, a PIN photodiode integrated with a trans-impedance preamplifier (TIA) and MCU control unit. All modules satisfy class I laser safety requirements. The transceivers are compatible with SFP Multi-Source Agreement (MSA) and SFF-8472. For further information, please refer to SFP MSA.

Functional Diagram

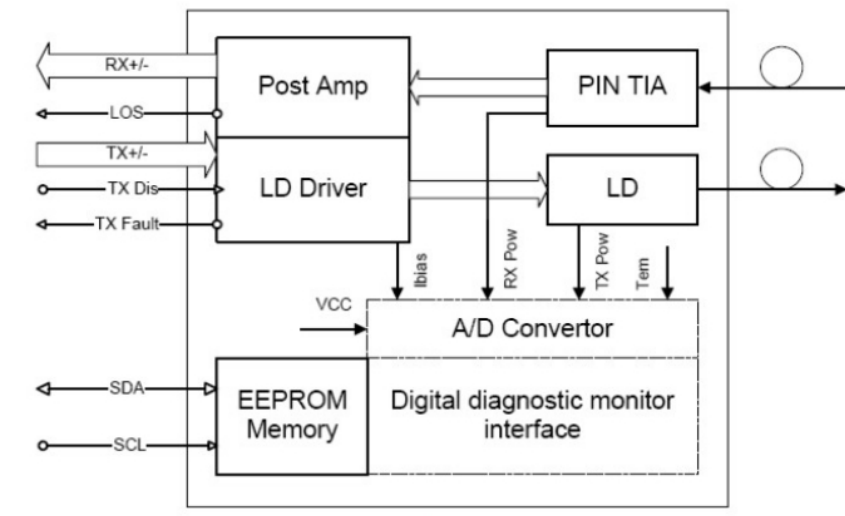



Absolute Maximum Ratings

Parameter	Symbol	Min.	Max.	Unit	Note
Supply Voltage	Vcc	-0.5	4.0	V	
Storage Temperature	Ts	-40	85	°C	
Relative Humidity	RH	0	85	%	

Note: Stress in excess of the maximum absolute ratings can cause permanent damage to the transceiver.

General Operating Characteristics

Parameter	Symbol	Min.	Typ	Max.	Unit	Note
Data Rate	DR		1.25		Gb/s	
Supply Voltage	Vcc	3.13	3.3	3.47	V	
Supply Current	Icc _s			250	mA	
Operating Case Temp.	Tc	0		70	°C	
	Tl	-40		85		

Electrical Characteristics (TOP(C) = 0 to 70 °C, TOP(I) = -40 to 85 °C, VCC = 3.13 to 3.47 V)

Parameter	Symbol	Min.	Typ	Max.	Unit	Note
Transmitter						
Differential data input swing	V _{IN,PP}	120		820	mV _{pp}	1
Tx Disable Input-High	V _{IH}	2.0		V _{cc} +0.3	V	
Tx Disable Input-Low	V _{IL}	0		0.8	V	
Tx Fault Output-High	V _{OH}	2.0		V _{cc} +0.3	V	2
Tx Fault Output-Low	V _{OL}	0		0.5	V	2
Input differential impedance	R _{in}		100		Ω	
Receiver						
Differential data output swing	V _{out,pp}	300	650	800	mV _{pp}	3
Rx LOS Output-High	V _{ROH}	2.0		V _{cc} +0.3	V	2
Rx LOS Output-Low	V _{ROL}	0		0.8	V	2

Notes:

1. TD+/- are internally AC coupled with 100Ω differential termination inside the module.
2. Tx Fault and Rx LOS are open collector outputs, which should be pulled up with 4.7k to 10kΩ resistors on the host board. Pull up voltage between 2.0V and Vcc+0.3V.
3. RD+/- outputs are internally AC coupled, and should be terminated with 100Ω (differential) at the user SERDES.

Optical Characteristics (TOP(C)= 0 to 70 °C, TOP(I) =-40 to 85 °C, VCC = 3.13 to 3.47 V)

Parameter	Symbol	Min.	Typ	Max.	Unit	Note
Transmitter						
Operating Wavelength	λ	$\lambda-7.5\text{nm}$	λ	$\lambda+7.5\text{nm}$	nm	1
Ave. output power (Enabled)	P _{AVE}	-8		-4	dBm	2
Extinction Ratio	ER	9			dB	2
Side-mode suppression ratio	SMSR	30			dB	
RMS spectral width	$\Delta\lambda$			1	nm	
Rise/Fall time (20%~80%)	T _r /T _f			0.26	ns	3
Dispersion penalty	T _{DP}			3.9	dB	
Output Optical Eye	ITU-T G.957 Compliant					
Receiver						
Operating Wavelength	λ		λ		nm	
Receiver Sensitivity	P _{SENI}			-22	dBm	4
Overload	P _{AVE}	0			dBm	4
LOS Assert	P _a	-35			dBm	
LOS De-assert	P _d			-24	dBm	
LOS Hysteresis	P _d -P _a	0.5			dB	

Notes:

- λ means 1270nm~1610nm ,Total 18wavelengths ,20nm spacing.
- Measured at 1.25Gb/s with PRBS $2^{23}-1$ NRZ test pattern.
- Unfiltered, measured with a PRBS $2^{23}-1$ test pattern @1.25Gbps
- Measured at 1.25Gb/s with PRBS $2^{23}-1$ NRZ test pattern for BER < 1×10^{-12}

Pin Defintion And Functionsm

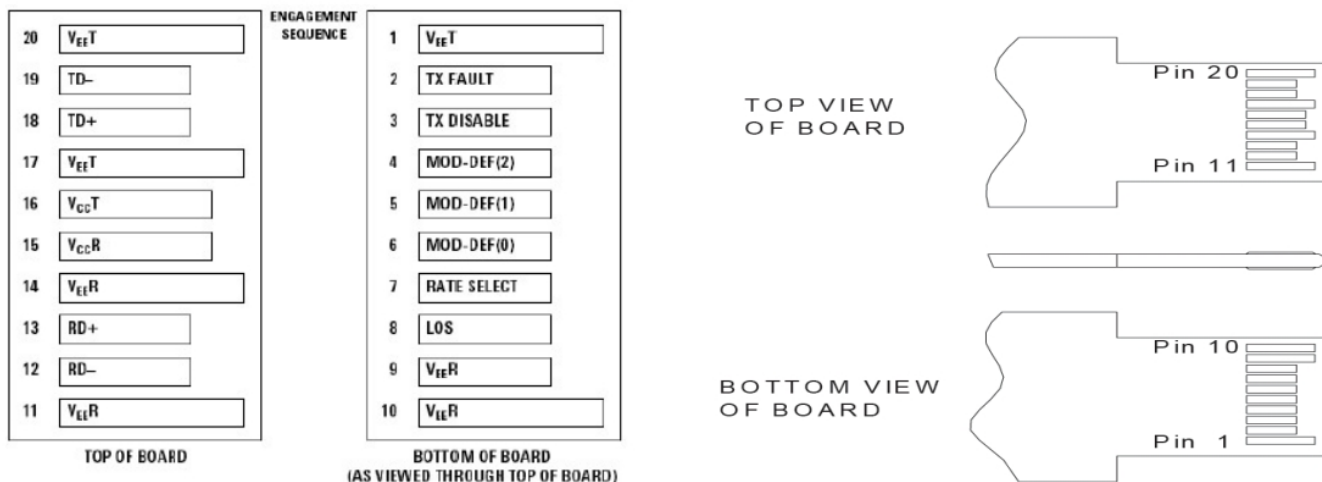

Pin	Symbol	Name/Description	Notes
1	V _{EE} T	Tx ground	

The OLSCxx12L-C(I)D20 transceivers can be used in host systems that require either internally or externally calibrated digital diagnostics.

Parameter	Symbol	Units	Min.	Max.	Accuracy	Note
Transceiver temperature	DTemp-E	°C	-45	+90	±5°C	1
Transceiver supply voltage	DVoltage	V	2.8	4.0	±3%	
Transmitter bias current	DBias	mA	2	80	±10%	2
Transmitter output power	DTx-Power	dBm	-9	-3	±3dB	
Receiver average input power	DRx-Power	dBm	-25	0	±3dB	

Notes:

1. When Operating temp.=0~70 °C,the range will be min=-5,Max=+75
2. The accuracy of the Tx bias current is 10% of the actual current from the laser driver to the laser
3. Internal/ External Calibration compatible.

Typical Interface Circuit

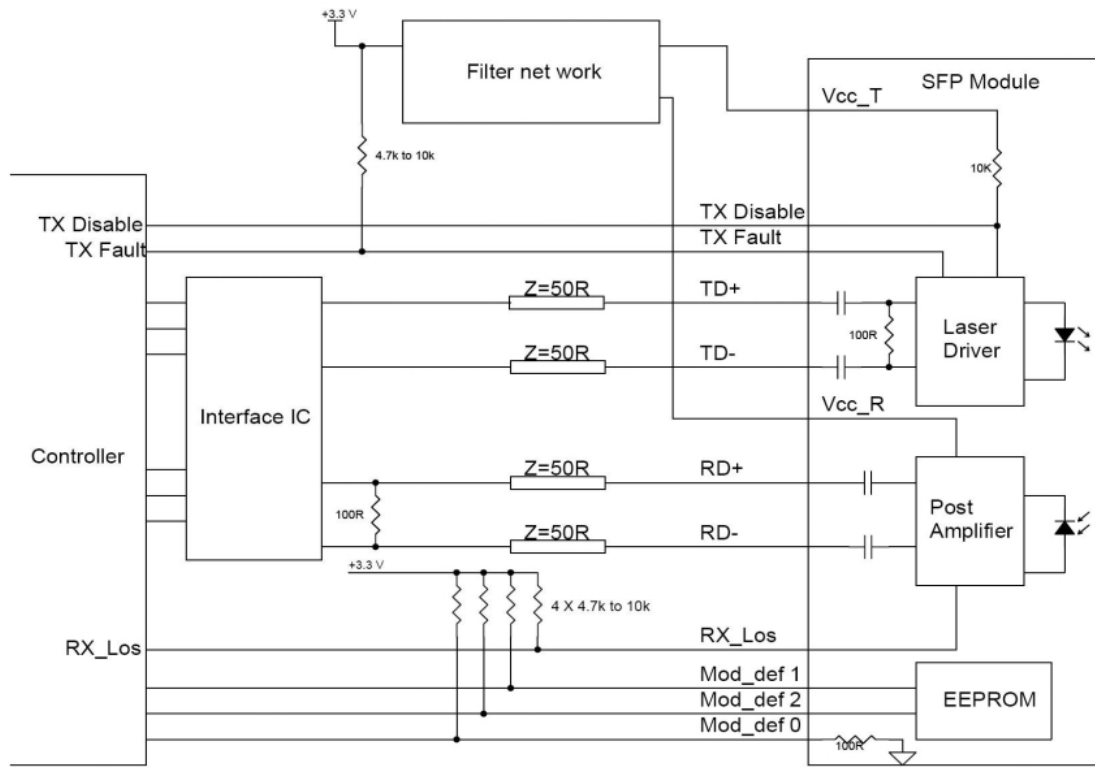

Package Dimensions

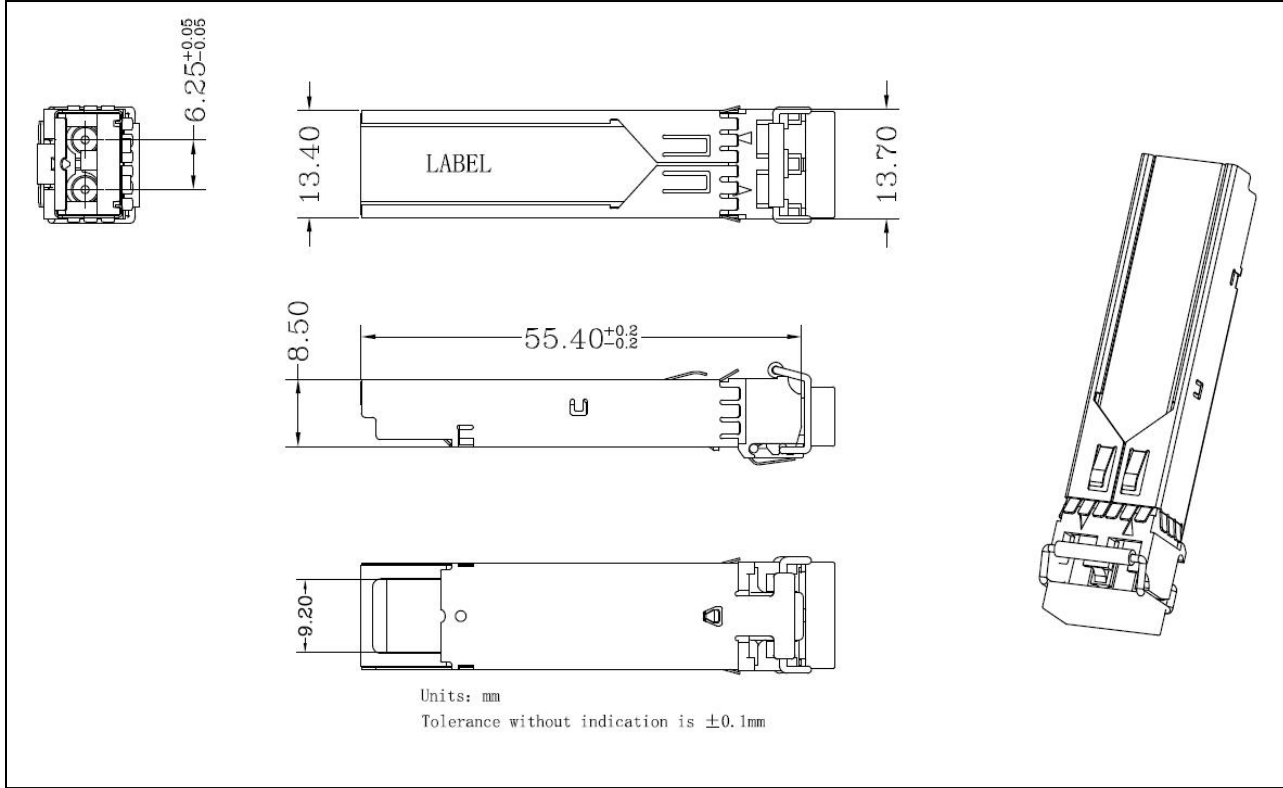

Product Selection(Color of Latches)

Wavel	XX	letter	Latch Color	Wavelength	XX	letter	Latch Color
1270n	27	A	Gray	1450nm	45	J	Brown
1290n	29	B	Gray	1470nm	47	K	Gray
1310n	31	C	Gray	1490nm	49	L	Violet
1330n	33	D	Violet	1510nm	51	M	Blue
1350n	35	E	Blue	1530nm	53	N	Green
1370n	37	F	Green	1550nm	55	O	Yellow
1390n	39	G	Yellow	1570nm	57	P	Orange
1410n	41	H	Orange	1590nm	59	Q	Red
1430n	43	I	Red	1610nm	61	R	Brown

Ordering Information

Part Number	Description
OLSCxx12L-CD20	SFP,1.25G, CWDM, 20Km, 0~70°C, with Digital Diagnostic Monitor
OLSCxx12L-ID20	SFP,1.25G, CWDM, 20Km, -40~85°C, with Digital Diagnostic Monitor
xx means	27=1270nm,29=1290nm,....59=1590nm,61=1610nm

For More Information

Shenzhen Olinkcom Technology Co.,Ltd

Olinkphotinics' Proprietary and Confidential, Do not Copy or Distribute without noticed



Add:4/F, No.2 Building, Delux Science and Technology City, No.5 Guanle Rd,Luhu Community, Guanlan Street,
Longhua District, Shenzhen, China
Tel: +86-755-27215326
Fax: +86-755-27217051
E-mail:sales@olinkphotonics.com
Website:www.olinkphotonics.com