

Product Specification Sheet

OLSDxx25L-ID80

RoHS Compliant 2.5Gb/s SFP DWDM 80km Optical Transceiver





Product Features

- Supports 2.5 Gb/s bit rates
- Duplex LC connector
- Hot pluggable SFP footprint
- Cooled DML transmitter and APD receiver
- Applicable for 80km SMF connection
- Low power consumption, < 1.5W
- Digital Diagnostic Monitor Interface
- Optical interface compliant to ITU-T 694.1& G.698.1
- Electrical interface compliant to SFF-8431& SFF-8432
- Operating case temperature:
Industrial:-40 to 85 °C

Applications

- 2.5G Ethernet
- ITU-T G.698.1
- Other optical links

Product Descriptions

Olinkphotonics' OLSDxx25L-ID80 Enhanced Small Form Factor Pluggable SFP transceivers are designed for use in 10-Gigabit Ethernet links up to 80km over SingleMode fiber. They are compliant with SFF- 8431,SFF-8432 and ITU-T G.698.1. The transceiver designs are optimized for high performance and cost effective to supply customers the best solutions for telecommunication.

This transceiver consists of two sections: The transmitter section incorporates a cooled DML laser. And the receiver section consists of a APD photodiode integrated with a TIA. All modules satisfy class I laser safety requirements. Digital diagnostics functions are available via a 2-wire serial interface, as specified in SFF-8472, which allows real-time access to device operating parameters such as transceiver temperature, laser bias current, transmitted optical power, received optical power and transceiver supply voltage.



Product Channel Selection

Channel#	Product Part No.	Frequency (THz)	Center Wavelength (nm)
17	OLSD1725L-ID80	191.7	1563.86
18	OLSD1825L-ID80	191.8	1563.05
19	OLSD1925L-ID80	191.9	1562.23
20	OLSD2025L-ID80	192.0	1561.42
21	OLSD2125L-ID80	192.1	1560.61
22	OLSD2225L-ID80	192.2	1559.79
23	OLSD2325L-ID80	192.3	1558.98
24	OLSD2425L-ID80	192.4	1558.17
25	OLSD2525L-ID80	192.5	1557.36
26	OLSD2625L-ID80	192.6	1556.55
27	OLSD2725L-ID80	192.7	1555.75
28	OLSD2825L-ID80	192.8	1554.94
29	OLSD2925L-ID80	192.9	1554.13
30	OLSD3025L-ID80	193.0	1553.33
31	OLSD3125L-ID80	193.1	1552.52
32	OLSD3225L-ID80	193.2	1551.72
33	OLSD3325L-ID80	193.3	1550.92
34	OLSD3425L-ID80	193.4	1550.12
35	OLSD3525L-ID80	193.5	1549.32
36	OLSD3625L-ID80	193.6	1548.51
37	OLSD3725L-ID80	193.7	1547.72
38	OLSD3825L-ID80	193.8	1546.92
39	OLSD3925L-ID80	193.9	1546.12
40	OLSD4025L-ID80	194.0	1545.32
41	OLSD4125L-ID80	194.1	1544.53
42	OLSD4225L-ID80	194.2	1543.73
43	OLSD4325L-ID80	194.3	1542.94
44	OLSD4425L-ID80	194.4	1542.14
45	OLSD4525L-ID80	194.5	1541.35
46	OLSD4625L-ID80	194.6	1540.56
47	OLSD4725L-ID80	194.7	1539.77
48	OLSD4825L-ID80	194.8	1538.98
49	OLSD4925L-ID80	194.9	1538.19
50	OLSD5025L-ID80	195.0	1537.40
51	OLSD5125L-ID80	195.1	1536.61
52	OLSD5225L-ID80	195.2	1535.82
53	OLSD5325L-ID80	195.3	1535.04
54	OLSD5425L-ID80	195.4	1534.25
55	OLSD5525L-ID80	195.5	1533.47
56	OLSD5625L-ID80	195.6	1532.68
57	OLSD5725L-ID80	195.7	1531.90
58	OLSD5825L-ID80	195.8	1531.12
59	OLSD5925L-ID80	195.9	1530.33
60	OLSD6025L-ID80	196.0	1529.55
61	OLSD6125L-ID80	196.1	1528.77



Functional Diagram

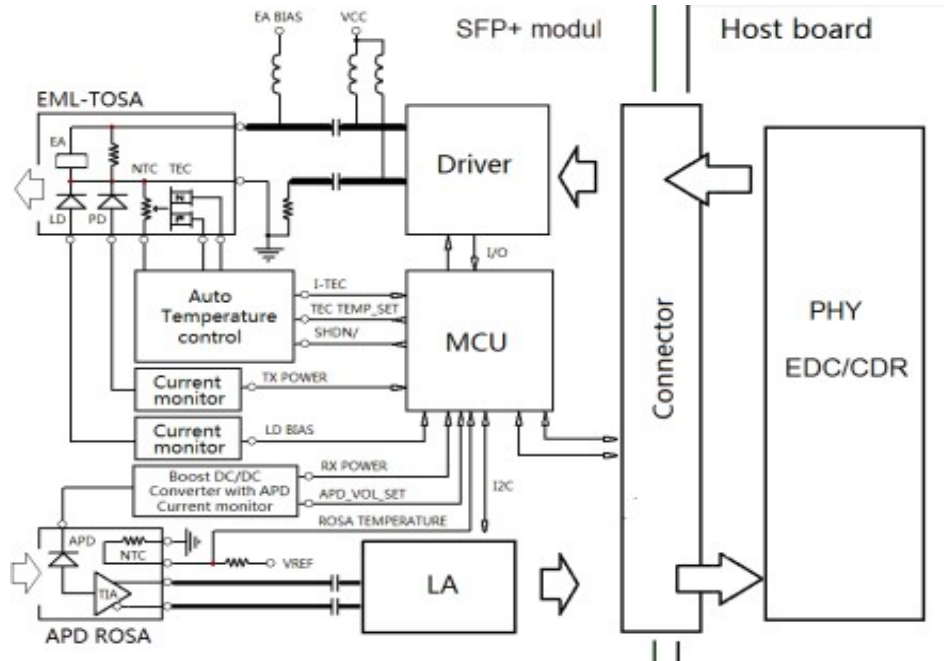

Absolute Maximum Ratings

Parameter	Symbol	Min.	Max.	Unit	Note
Supply Voltage	Vcc	-0.5	4.0	V	
Storage Temperature	Ts	-40	85	°C	
Relative Humidity	RH	0	85	%	

Note: Stress in excess of the maximum absolute ratings can cause permanent damage to the transceiver.

General Operating Characteristics

Parameter	Symbol	Min.	Typ	Max.	Unit	Note
Data Rate	DR		2.5		Gb/s	
Supply Voltage	Vcc	3.13	3.3	3.47	V	
Supply Current	Icc _s			450	mA	
Operating Case Temp.	Ti	-40		85	°C	

Electrical Characteristics (T_{OP(I)} = -40 to 85 °C, V_{CC} = 3.13 to 3.47 V)

Parameter	Symbol	Min.	Typ	Max.	Unit	Note
Transmitter						
Differential data input swing	V _{IN,PP}	120		850	mV _{pp}	
Transmit Disable Voltage	V _D	V _{CC} -0.8		V _{CC}	V	
Transmit Enable Voltage	V _{EN}	V _{EE}		V _{EE} +0.8	V	
Input differential impedance	R _{in}		100		Ω	
Receiver						
Differential data output swing	V _{out,pp}	340		800	mV _{pp}	
Output rise time and fall time	T _r , T _f	28			Ps	1
LOS asserted	V _{LOS_F}	V _{CC} -0.8		V _{CC}	V	2
LOS de-asserted	V _{LOS_N}	V _{EE}		V _{EE} +0.8	V	2

Notes:

- 20 – 80%. Measured with Module Compliance Test Board and OMA test pattern. Use of four 1's and four 0's sequence in the PRBS 9 is an acceptable alternative.
- LOS is an open collector output. Should be pulled up with 4.7kΩ – 10kΩ on the host board. Normal operation is logic 0; loss of signal is logic 1.

Optical Characteristics (T_{OP(I)} = -40 to 85 °C, V_{CC} = 3.13 to 3.47 V)

Parameter	Symbol	Min.	Typ	Max.	Unit	Note
Transmitter						
Center Wavelength	λ _c	λ-0.1nm	λ	λ+0.1nm	nm	
Center Wavelength (End of Life)	λ _{c_EOL}		λ _c ±100pm			
Ave. output power (Enabled)	P _{AVE}	0		5	dBm	1
Side-Mode Suppression Ratio	SMSR	30			dB	
Extinction Ratio	ER	8.2			dB	
RMS spectral width	Δλ			1	nm	
Rise/Fall time (20%~80%)	T _r /T _f			50	ps	
Relative Intensity Noise	R _{IN}			-128	dB/Hz	
Receiver						
Operating Wavelength	λ	1260		1600	nm	
Receiver Sensitivity	P _{SEN}			-28	dBm	2
Overload	P _{AVE}	-7			dBm	
LOS Assert	P _a	-45			dBm	
LOS De-assert	P _d			-29	dBm	
LOS Hysteresis	P _d -P _a	0.5			dB	

Notes:

- Measured 2²³-1 PRBS@2.5G
- Measured with worst ER=8.2dB; 2²³-1 PRBS@2.5G

Pin Defintion And Functions

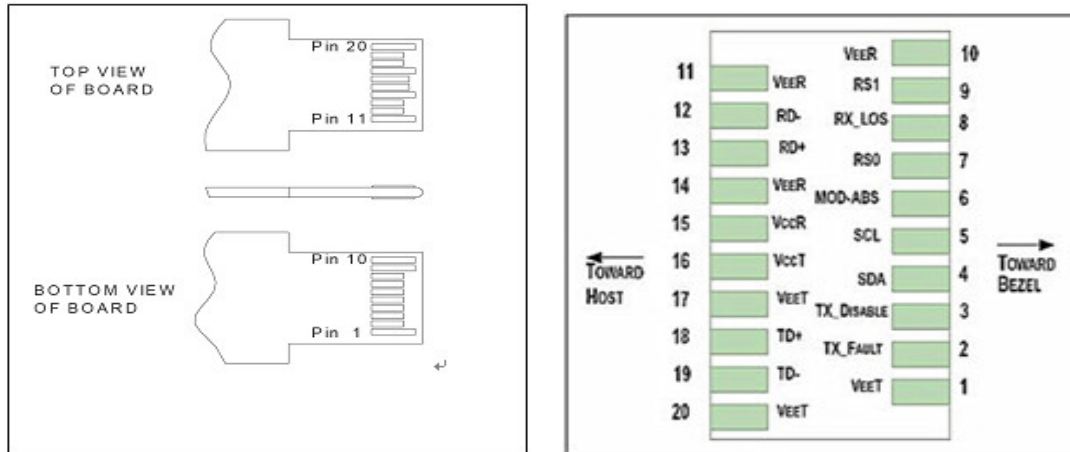

Pin	Symbol	Name/Description
1	VEET [1]	Transmitter Ground
2	Tx_FAULT [2]	Transmitter Fault
3	Tx_DIS [3]	Transmitter Disable. Laser output disabled on high or open
4	SDA [2]	2-wire Serial Interface Data Line
5	SCL [2]	2-wire Serial Interface Clock Line
6	MOD_ABS [4]	Module Absent. Grounded within the module
7	RS0	Rate Select 0
8	RX_LOS [2]	Loss of Signal indication. Logic 0 indicates normal operation
9	RS1	Rate Select 1
10	VEER [1]	Receiver Ground
11	VEER [1]	Receiver Ground
12	RD-	Receiver Inverted DATA out. AC Coupled
13	RD+	Receiver DATA out. AC Coupled
14	VEER [1]	Receiver Ground
15	VCCR	Receiver Power Supply
16	VCCT	Transmitter Power Supply
17	VEET [1]	Transmitter Ground
18	TD+	Transmitter DATA in. AC Coupled
19	TD-	Transmitter Inverted DATA in. AC Coupled
20	VEET [1]	Transmitter Ground

Notes:

1. Module circuit ground is isolated from module chassis ground within the module.
2. should be pulled up with 4.7k – 10k ohms on host board to a voltage between 3.15V and 3.6V.
3. Tx_Disable is an input contact with a 4.7 kΩ to 10 kΩ pullup to VccT inside the module.
4. Mod_ABS is connected to VeeT or VeeR in the SFP+ module. The host may pull this contact up to Vcc_Host with a resistor in the range 4.7 kΩ to 10 kΩ. Mod_ABS is asserted “High” when the SFP+ module is physically absent from a host slot.

Serial Interface for ID and Digital Diagnostic Monitor

The OLSDxx25L-ID80 transceiver support the 2-wire serial communication protocol as defined in the SFP+ MSA. The standard SFP+ serial ID provides access to identification information that describes the transceiver’s capabilities, standard interfaces, manufacturer, and other information. Additionally, This SFP+ transceivers provide an enhanced digital diagnostic monitoring interface, which allows real-time access to device operating parameters such as transceiver temperature, laser bias current, transmitted optical power, received optical power and transceiver supply voltage. It also defines a sophisticated system of alarm and warning flags, which alerts end-users when particular operating parameters are outside of a factory set normal range.

The SFP MSA defines a 256-byte memory map in EEPROM that is accessible over a 2-wire serial interface at the 8 bit address 1010000X(A0h), so the originally monitoring interface makes use of the 8 bit address(A2h), so the originally defined serial ID memory map remains unchanged. The structure of the memory map is shown in Table1.

2 wire address 1010000X (A0h)		2 wire address 1010001X (A2h)	
Address	Information	Address	Information
0~95	Serial ID Defined by SFP MSA (96 bytes)	0~55	Alarm and Warning Thresholds (56 bytes)
96~127	Vendor Specific (32 bytes)	56~95	Calibration Constants (40 bytes)
128~255	Reserved,SFF8079 (128 bytes)	96~119	Real Time Diagnostic Interface (24 bytes)
		120~127	Vender Specific (8 bytes)
		128~247	User Writable EEPROM (120 bytes)
		248~255	Vender Specific (8 bytes)}

Table 1. Digital Diagnostic Memory Map (Specific Data Field Descriptions)

Typical Interface Circuit

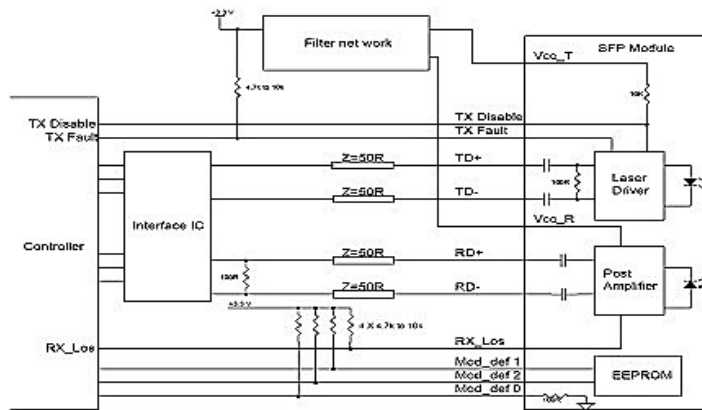

Recommended power supply filter

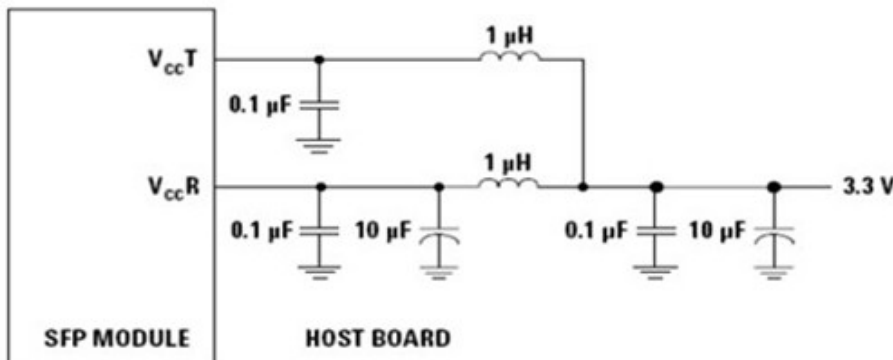



Note:

Inductors with DC resistance of less than 1Ω should be used in order to maintain the required voltage at the SFP input pin with 3.3V supply voltage. When the recommended supply filtering network is used, hot plugging of the SFP transceiver module will result in an inrush current of no more than 30 mA greater than the steady state value

Package Dimensions

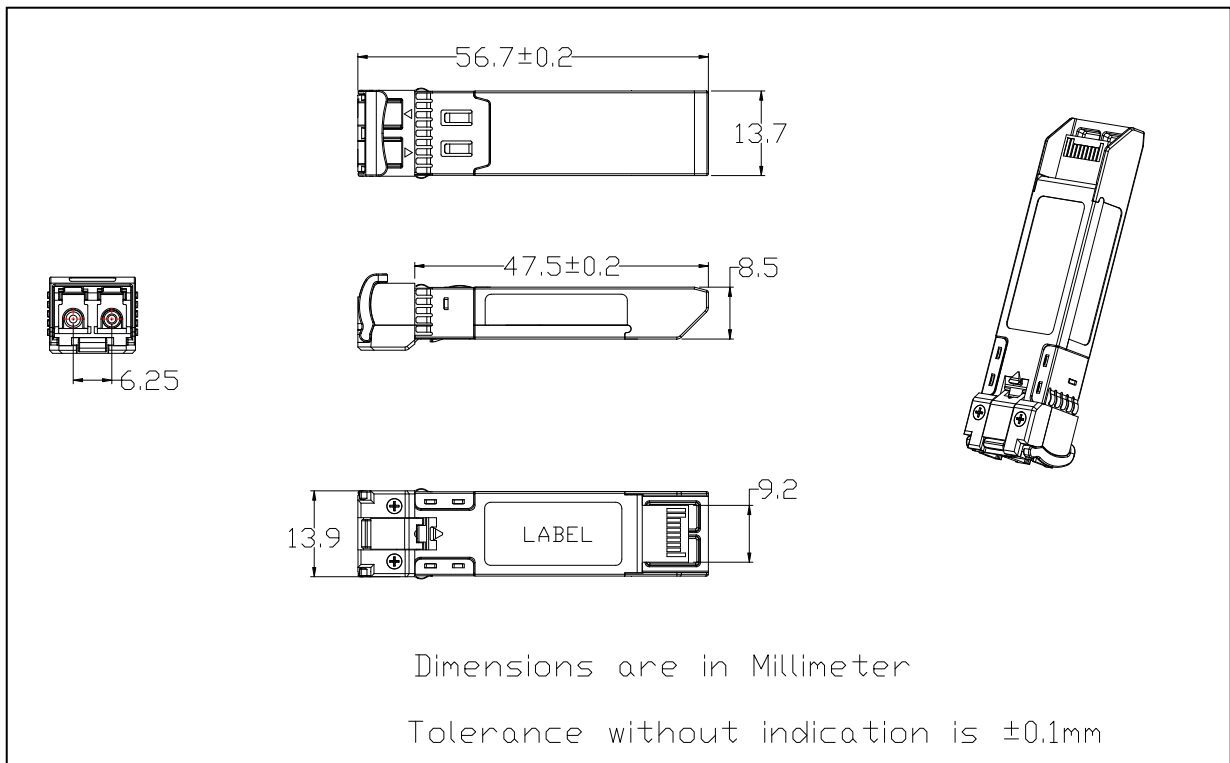

Ordering Information

Part Number	Description
OLSDxx25L-ID80	SFP,2.5Gb/s, DWDM wavelengths,80km, -40~85°C, with Digital Diagnostic Monitor
xx Means:	Refer to “ Product Channel Selection ”

For More Information

Shenzhen Olinkcom Technology Co.,Ltd

Add:4/F, No.2 Building, Delux Science and Technology City, No.5 Guanle Rd,Luhu Community, Guanlan Street, Longhua District, Shenzhen, China

Tel: +86-755-27215326

Fax: +86-755-27217051



E-mail:sales@olinkphotonics.com

Website:www.olinkphotonics.com